

Operating Manual

Retrofit Speed-Controller Type ECD3AM-00-00

Replacement for

ECdrive Type D400B001, Ziehl-Abegg

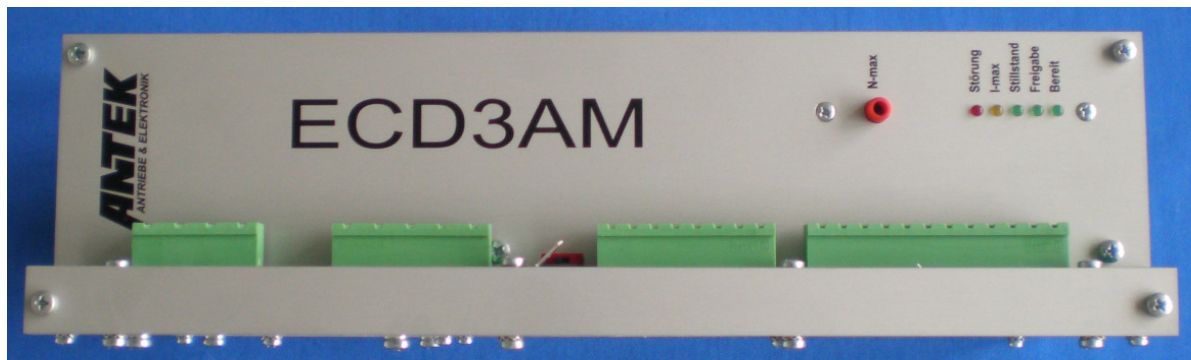

Content:

	Page
1. SAFETY INFORMATION	3
2. TECHNICAL DATA	4
2.1 CONTROLLER ECD3AM	4
2.2 DIMENSIONS	5
3. INSTALLATION	6
3.1 MECHANICAL INSTALLATION	6
3.2 ELECTRICAL INSTALLATION	6
3.3 INFORMATION ON EMC	7
3.4 ELECTRICAL CONNECTION CONTROLLER	8
3.5 OPERATING - AND DISPLAY ELEMENTS	9
3.6 ADJUSTMENT	9
3.7 ADJUSTMENTS INTERNAL	10
3.8 CODING - JUMPERS INTERNALLY	11
3.9 BLOCK DIAGRAM	12
4. MANUFACTURER'S DECLARATION	13

-Errors and revisions are reserved-

ANTEK GmbH
Im Köchersgrund 1
71717 Beilstein

 +49 7062 94060
 +49 7062 940620
 info@antek-online.de
 www.antek-online.de

1. Safety information

Electrical units are a source of danger.



Comply with the relevant laws and regulations when electrical units are used in installations and control systems which require observation of safety rules, and when carrying out installation work.

When working on live units, always comply with the current accident prevention regulations.

For reasons of safety and in order to maintain the documented system data and functions the unit or its components may only be repaired by the manufacturer.

No liability can be accepted if the drive parameters have an unsuitable, incorrect manual or automatic setting.

Incorrect handling may cause injuries and/or damage property!

Prior to installation technicians who are familiar with electrical drive equipment must read the unit handbook thoroughly.

Ensure that the voltage is less than 60V before touching electrical contacts.

The user must use independent monitoring units in order to ensure that a malfunctioning drive is stopped safely.

The user is responsible for installing and connecting the motor, the converter and auxiliary units pursuant to the acknowledged technical rules in the country of installation and other current regional regulations. In particular, cable dimensioning, shielding, earthing, disconnection, isolation and overcurrent protection must be taken into account.

Regulations pursuant to DIN 57100 are applicable.

The modules are fitted with electrostatically sensitive CMOS and MOS components. Always comply with the following information when handling and testing the units, otherwise these integrated circuits may be damaged.

- ◆ When servicing the unit, first ensure that there is equipotential bonding (static charging) between the unit, tools, measuring instruments and personnel.
- ◆ Take hold of the modules only by the edges; do not touch the components or their connections.

2. Technical Data

2.1 Controller ECD3AM

Mains input voltage:	U_N	400 VAC, 45 ... 64 Hz
Nominal input current:	I_N	3 AAC
Internal fuse:		6,3 AT
Output voltage	U_M	0 ... 90% UZK
Max. output current:	I_{Mmax}	6,5 A / Phase
Continuous output current:	I_M	3 A / Phase
Rated output power ¹ :	S_N	0,9 kVA
Efficiency:	η	ca. 95%
Power loss idling ²	P_{V0}	ca. 18 W
Power loss full load:	P_V	ca. 50 W
Max. heatsink temperature:	ϑ	ca. 80 °C
Control range:		1 : 40
Device version		IP20
Standards and regulations:		see Page 13

¹ In relation to the mains voltage 400 VAC

² Losses in 3A and phase current 12 kHz clock frequency

2.2 Dimensions

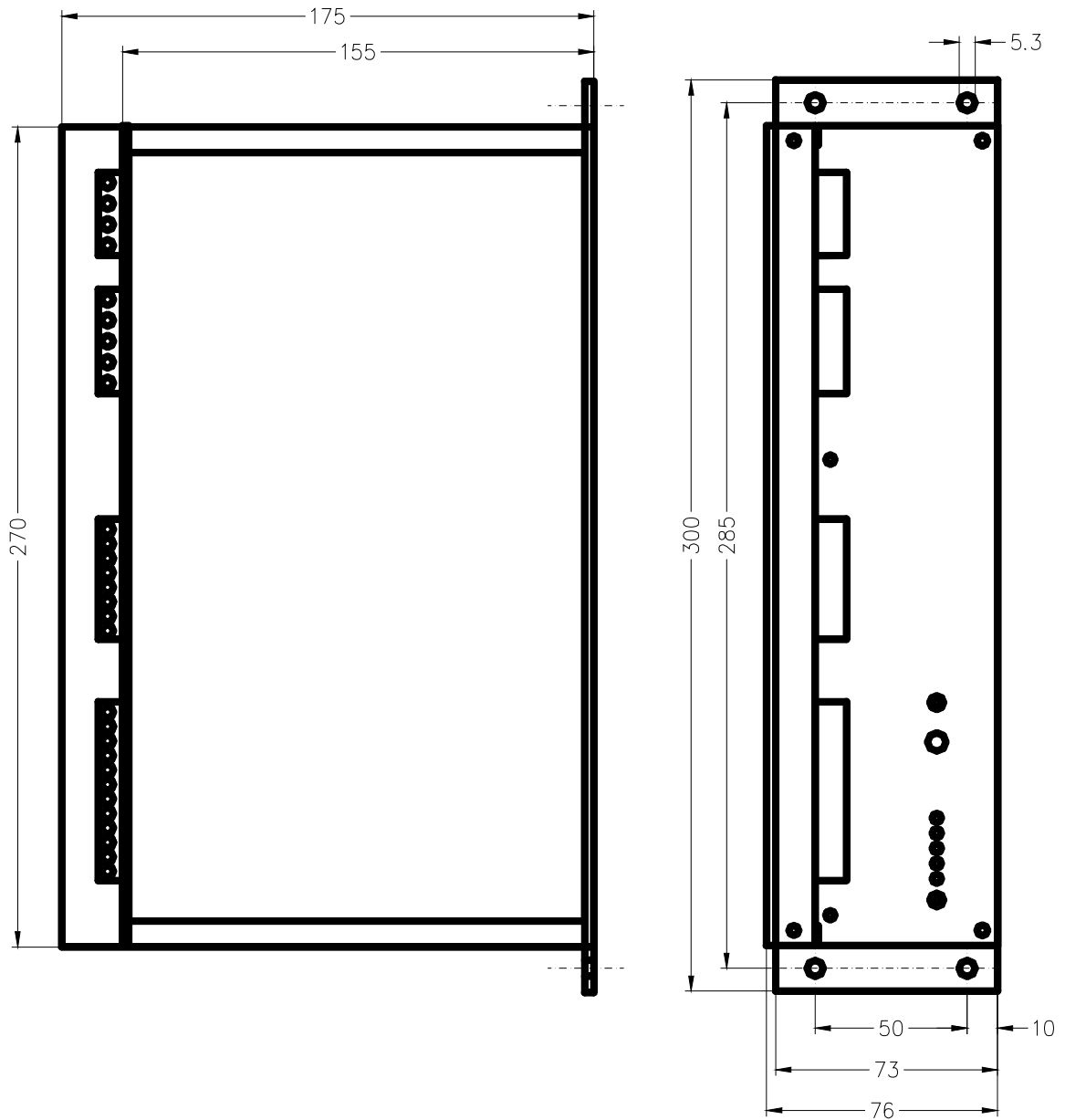

3. Installation

3.1 Mechanical Installation

- ◆ Das Controller may only be installed in an upright position.
- ◆ A clearance of 50 mm must be maintained both above and below the controller
- ◆ An unobstructed inflow of cooling air and outflow of exhaust air must be ensured.
- ◆ Appropriate counter-measures must be taken if the cooling air contains impurities (dust, fluff, corrosive gases and grease) impairing operation of the controller, e.g. separate air guidance, installation of filters, regular cleaning, etc.
- ◆ The ambient temperature range must not be exceeded during operation.
- ◆ Shock absorbing elements may be necessary if the controller is continuously exposed to vibrations or impacts during operation.

3.2 Electrical Installation

- ◆ The controller contains components sensitive to electrostatics. Before installation and service work in the terminal clamp area, the staff must free itself of electrostatic electricity. The discharging can be achieved by touching a grounded metal surface beforehand.
- ◆ Due to the leakage currents of the controller (> 3.5 mA) via the protective conductor (PE) must be in accordance with DIN EN 50178 the cable cross section of the protective conductor to the cabinet at least 10 mm² Cu, or it must be laid electrically parallel, a second protective conductor. For larger power ratings of minimum cross-section of the protective conductor must be in appropriate relation to the cross section of the outer conductor.
(see DIN 0100 Part 540)
- ◆ The provisions on minimum cross sections of PE conductors must be maintained. The cross-section of the PE conductor must be at least as large as the cross section of the power connections.
- ◆ Perform safety disconnection between the controller from the mains via an input-side mains contactor.
- ◆ It is recommended that the motor temperature monitoring conduct by thermal circuit breaker.
- ◆ Set point input, analog control inputs and measurement outputs are to be laid with shielded cables.
- ◆ Conductor diameters for power supply and motor wiring must be at least 1,5 mm²!
- ◆ Observe the current local safety regulations

3.3 Information on EMC

In order to warranty electromagnetic compatibility (EMC) in your switch cabinets in an electrically raw environment, the following EMC rules are to be observed during construction and set-up:

- ◆ All metallic parts of the switch cabinet are to be connected flatly and in a well-conducting manner (not lacquer on lacquer!). If necessary, use contact or scraper wafers. The cabinet door is to be connected with as short a circuit as possible via the metal powder tapes (upper, middle, lower).
- ◆ Signal lines and power cables are to be laid separated from each other in order to avoid coupling intervals. Minimum distance: 20 cm:
- ◆ Signal lines should be led to the cabinet from only one level, if possible. Unshielded lines from the same electrical circuit (outgoing and return circuit) are to be transposed, if possible.
- ◆ Contactors, relays and magnetic valves in the switch cabinet, if necessary in the adjacent cabinets, are to be wired with suppressor combinations, e.g. with RC elements, varistors or diodes.
- ◆ The braiding from signal lines are to be laid two-way (source and target), large-area and well-conducting to a ground¹. In case of poor potential equalization between shielded connections, an additional balancing network of at least 10 mm² must be laid parallel to the braiding to reduce the current.
- ◆ Wiring is not to be laid freely in the cabinet, but should rather lead as tightly as possible to the cabinet frame or to installation plates. This also applies to reserve cables. At least one end of them must be grounded, but preferably both (additional shield effect).
- ◆ Unnecessary wire lengths are to be avoided. Coupling capacities and coupling inductance's are thereby kept small.
- ◆ The braiding from leads, such as resolver or incremental tachometer cables, must be laid to the frame grounding. Approximately 2 cm of the insulation is to be removed in the area where the cable is to be led into the frame in order to expose the braided cable. The braided cable may not be damaged while removing the insulation. The cable is to be led at the position where the insulation has been removed by grounded terminals or taut supports.

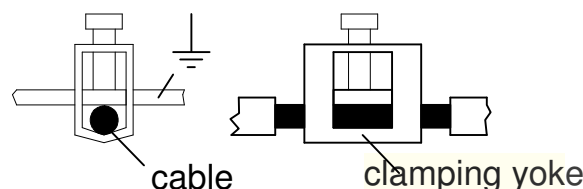

¹Generally all metallic conducting parts which can be connected to a protective conductor, such as cabinet frames, motor frames, foundation grounding, etc. are designated as a ground.

3.4 Electrical Connection Controller

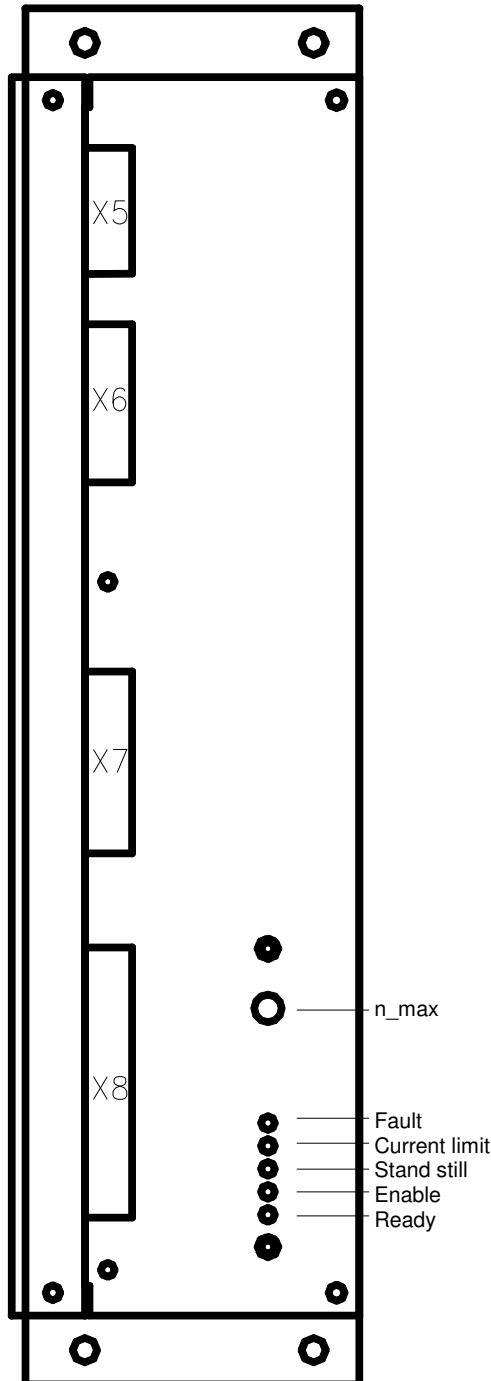
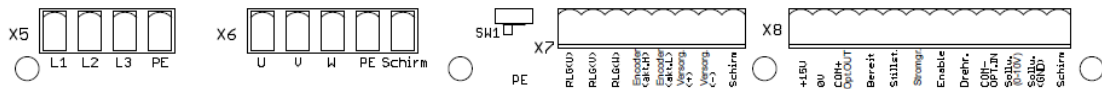

X5 Connector for power supply (400 V / 3~ / 50/60 Hz)

- 1 = L1
- 2 = L2
- 3 = L3
- 4 = PE

X6 Connector for motor connection

- 1 = U
- 2 = V
- 3 = W
- 4 = PE
- 5 = Shield

X7 Connector for control lines (Motor)

- 1 = RLG (U)
- 2 = RLG (V)
- 3 = RLG (W)
- 4 = Encoder active High (n.c.)
- 5 = Encoder active Low
- 6 = Supply voltage +
- 7 = Supply voltage -
- 8 = Shield

X8 Connectors for signal lines

- 1 = +15 V
- 2 = 0 V
- 3 = Com. + Opt.out
- 4 = Ready
- 5 = Stand still
- 6 = Current limit
- 7 = Controller enable
- 8 = Direction of rotation
- 9 = Com. - Opt. in
- 10 = Set point (0...10 V)
- 11 = Set point (GND)
- 12 = Shield

3.5 Operating - and display elements

Fault (RD)	Indicates a fault
Current limit (YE)	Indicates that the permissible peak current has been exceeded.
Stand still (GN)	Indicates the reaching of an engine speed <5 U/min.
Enable (GN)	Indicates the active ENABLE input
Operation (GN)	ON = Controller ready OFF= Controller collective fault <ul style="list-style-type: none">- Intermediate circuit > 450 V- Intermediate circuit < 150 V- Heat sink temperature > 80°C If there is a fault, the output stage is disabled immediately. The fault is stored until acknowledgment. The acknowledgment of the fault message is given to the removal of the controller enable.

3.6 Adjustment

n-max	Setting the maximum speed <ol style="list-style-type: none">1. Maximum set point voltage (10V) preset.2. On trimmer "n-max" adjust the required max. speed Setting range: about 1600-3100 U / min ¹ Factory setting: 3000 min ⁻¹
--------------	--

3.7 Adjustments internal

OFFSET

Speed offset adjustment can only be set in the device set point input to "0".

Enable controller,

ENABLE active. Adjust with trimmer "OFFSET" the engine at standstill.

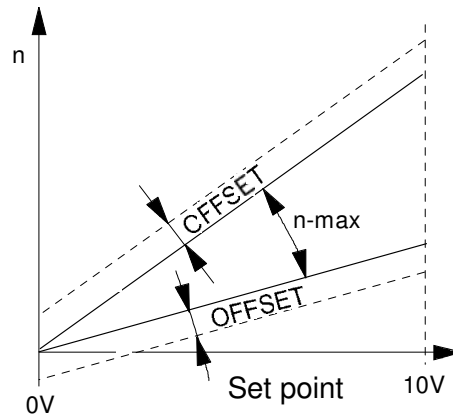

I-max

Internal factory setting may not be changed!

tH

Ramp-up time of the set point integrator

tR

Return time of the set point integrator

Setting the set point ramp

Set point jump (0 □ 10V) preset at set point input and adjust with trimmer "tH" or "tR" the required speed ramp.

Setting range: 100 ms ... 2 s

Factory setting: 100 ms

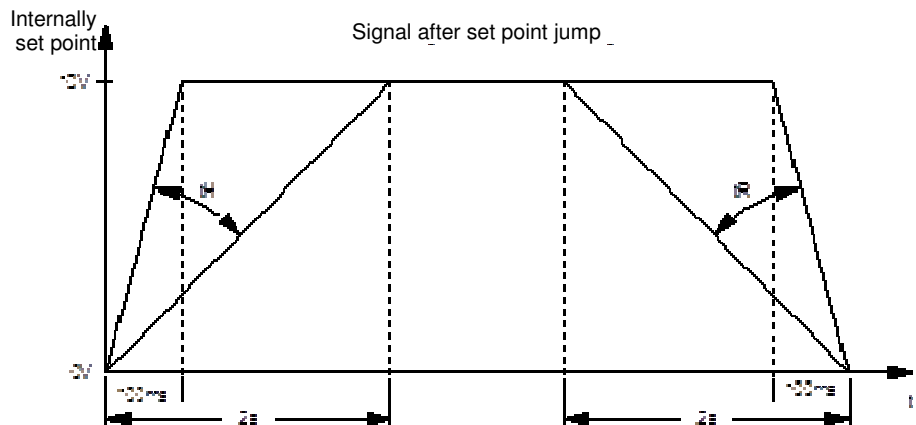

PI

Setting the speed controller behavior. Customize if necessary, on the particular application. Clockwise rotation increases the proportional gain.

Incorrectly adjusted control behavior leads to oscillation of the drive, which can damage the motor or the after switched components (etc. gearbox). The manufacturer takes no liability for damages by an incorrect parameter.

3.8 Coding - jumpers internally

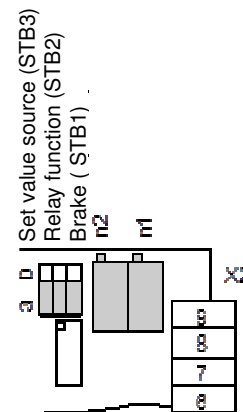
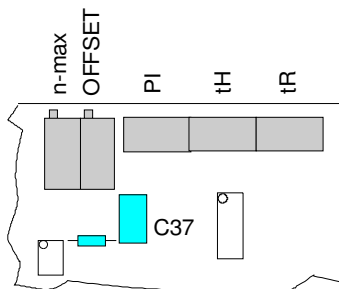

STB1
Brake

Jumper position a

A cut-off of the control voltage on connecting terminal 2-5 and/or X2-6 causes the motor to come to a standstill. This is the normal operation mode of the control device.

Jumper position b with brake function for positioning

After the cut-off of the control voltage the motor winding is short-circuited. The current is dependent upon the braking energy and must not exceed 8 A, otherwise the motor or the control device could be destroyed. Is the bridge put in position a, for damage caused to the engine or controller, no liability is assumed.

STB2, STB3

not in use!

3.9 Block diagram

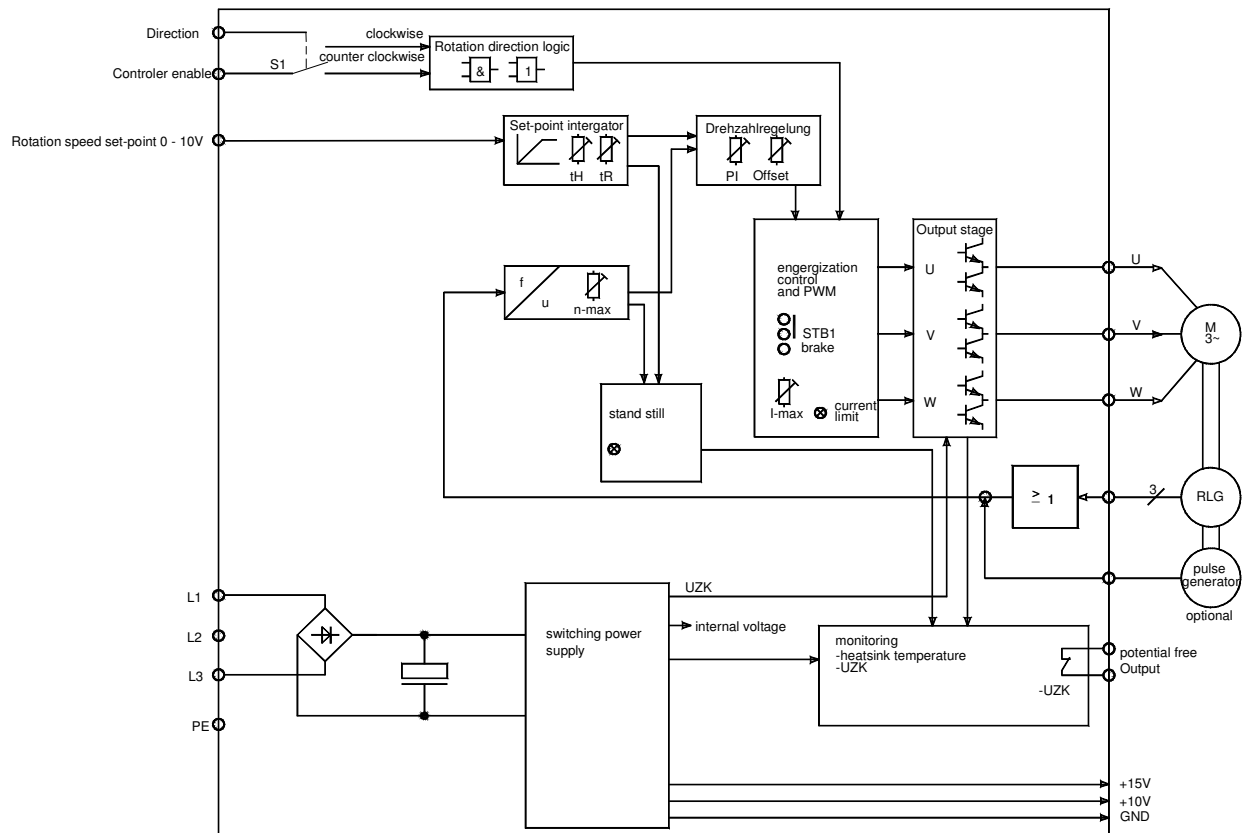

4. Manufacturer's declaration

The manufacturer, ANTEK GmbH, herewith declares that the drive regulator ECE3AP must be used as a component of the control equipment for variable speed motors to be installed in a machine or to be used for the construction of a machine together with other components. The drive regulators are not machines as defined in the machine guideline 89/392/EWG.

Notes and recommendations for the installation and proper operation are included in this technical documentation.

The start-up of the machine is prohibited until it has been determined that the protection and safety requirements of the machine guideline 89/392/EWG including revisions 68/EWG are fulfilled.

In this technical documentation, the measures are described with which the drive regulator complies with the EMC-limiting values. The electromagnetic compatibility of the machine is based on the method and thoroughness of the conducted installation. The User is responsible for the compliance of the EMC guideline 89/336/EWG including the revisions 92/31/EWG during operation of the machine.

Norms and regulations observed

- ◆ Installation of high-voltage current plants with electrical operating equipment: DIN VDE 0160
- ◆ Regulations for the set-up of high-voltage current plants: DIN VDE 0100
- ◆ IP-protection systems: EN 60529
- ◆ Basis material for printed circuits: DIN IEC 249 Part 1
- ◆ Printed circuits, circuits boards: DIN IEC 326 Part 1
- ◆ Regulation of air and flow routes: DIN VDE 0110 Part 1-2
- ◆ De-charging of statically electricity (ESD): EN 50082-2
- ◆ Rapid transient interference factors (Burst): EN 50082-2
- ◆ Radio shielding of electrical operating equipment and plants: EN 50081-2, EN 55011